

PowerView® PV101 Engine and Diagnostic Display

The PowerView PV101 display is a multifunction tool that enables equipment operators to view standard engine and transmission parameters and active/stored trouble codes. The display can show a single or a four-parameter simultaneous display with text descriptions for most common fault conditions. The enhanced alarm indicators have ultra-bright alarm and shut-down LEDs.



All models Tier 3/Euro Stage III and earlier (PV101-A) and Tier 4/Euro Stage IV (PV101-C-T4) share the following features:

- Multiple language options – English, Spanish, German, Italian, French, Brazilian Portuguese, Chinese, Japanese, Czech and Russian.
- Sender Input – Select between backlight dimmer function or fuel level. Can be calibrated to use non-Murphy fuel senders.
- Service Reminders – Five service reminders allow users to set hours for: Change Engine Oil, Air Filters, Hydraulic Oil, and Service Engine and Service Machine.
- Select Source Address – Select the exact address the PV101 will claim on the bus.
- The ability to select CAN bus Data Rate.
- Displays more than 50 standard SAE J1939 parameters.
- Shows helpful troubleshooting description of supported parameters.

Additional features for the Tier 4/Euro Stage IV (PV101-C-T4) models include:

- The menu offers Auto Regen, Request Regen and Inhibit Regen. Visible icons indicate:
 - Active Regeneration
 - Diesel Exhaust Fluid Level (DEF)
 - Diesel Particulate Filter (DPF) Restricted
 - Inhibit Regeneration or High Exhaust Temp
 - After Treatment Fault
- OEM Menu – A password protected menu offers access to MODBUS Setup, Engine Speed Control ON/OFF, DEF Regen Menu ON/OFF, SCR Enable Disable and other critical menu items that require restricted access.
- TSC1 (Torque Speed Control) – Allows users to set run speed via CAN if supported by engine manufacturer.
- Additional 4-Up Screen – Allows user to have two 4-Up screens to toggle between. Second user configurable screen is defaulted to show Tier 4 Parameters: DEF Level (Diesel Exhaust Fluid Level), DPF Active Regen Status, Exhaust Filter Outlet Temp and Exhaust Filter Inlet Temp. Shows SPN, FMI and OC for all faults.
- PV101-C Configuration Tool – PC tool allows users to create, view, edit and download configurations for the PV101-C.

Dimensions

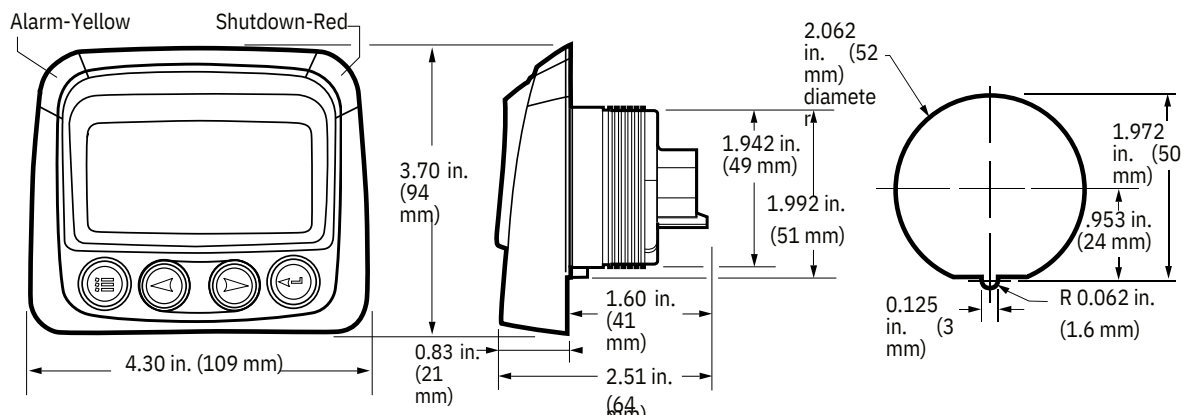

Specifications

Operating Voltage: 8 - 32 VDC

Reversed Polarity: Withstands reversed battery terminal polarity indefinitely within operating temperatures

Environmental

Operating Temperature: -40° to 185° F (-40° to 85° C)

Display Viewing Temperature: -20° to 185° F (-29° to 85° C)

Storage Temperature: -40° to 185° F (-40° to 85° C)

Environmental Sealing: IP68, ± 5 PSI (± 34 kPa)

Power Supply Operating Current

(@ 14 VDC) 52 mA min., 300 mA max

(@ 32 VDC) 1A max (with LCD heater)

CAN Bus: SAE J1939 compliant

Case: Polycarbonate/polyester

Maximum Panel Thickness: 3/8 inch (9.6 mm)

Auxiliary RS485 Communications Port:

User configurable as Modbus Master or Modbus RTU Slave

Master Active (default) drives optional PVA or PVM gages

Slave Active offers user adjustable communication parameters

Resistive Input: User selectable as one of the following

Backlighting Potentiometer: 1 K Ohm, 1/4 W

Murphy Fuel Sender: 33 Ohm full, 240 Ohm empty set standard from factory for use with Murphy fuel sender. Programmable for use with non-Murphy fuel senders.

Shipping Weight: 1 Lb. (450 g.)

Shipping Dimensions: 5 x 6 x 6 in. (127 x 152 x 152 mm)

Clamp: PBT

Connectors: 6-pin Deutsch DT Series

Pinout

DEUTSCH DT06-6 STYLE CONNECTIONS

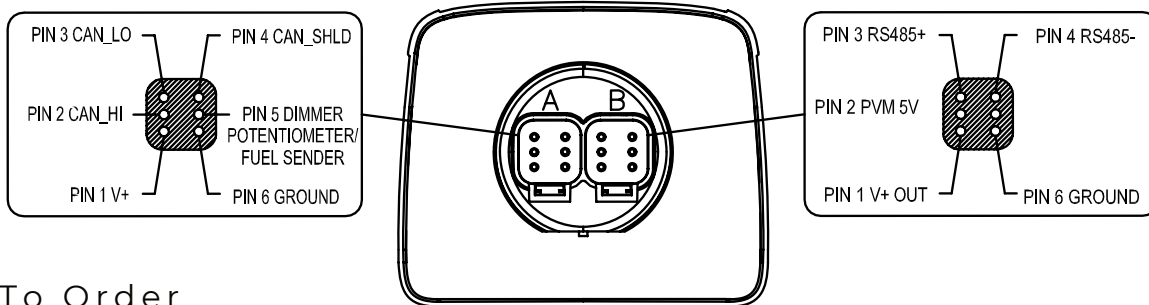

How To Order

Part Number	Model	Description	Languages Available
78700615	PV101-C-MSTD-TIER4	Murphy STD	English, Spanish, French, Italian, German
78700610	PV101-C-M01-TIER4	Murphy STD Russian	English, Russian
78700611	PV101-C-M02-TIER4	Murphy STD Chinese	English, Chinese
78700612	PV101-C-M03-TIER4	Murphy STD Japanese	English, Japanese
78700613	PV101-C-M04-TIER4	Murphy STD Brazilian Portuguese	English, Brazilian Portuguese, French, German, Spanish
78700614	PV101-C-M05-TIER4	Murphy STD Czech	English, Czech, French, German, Spanish
78700439	PV101-C	Murphy STD	English, Spanish, French, Italian, German
78700497	PV101-C-M01	Murphy STD Russian	English, Russian
78700498	PV101-C-M02	Murphy STD Chinese	English, Chinese
78700499	PV101-C-M03	Murphy STD Japanese	English, Japanese
78700500	PV101-C-M04	Murphy STD Brazilian Portuguese	English, Brazilian Portuguese, French, German, Spanish
78700501	PV101-C-M05	Murphy STD Czech	English, Czech, French, German, Spanish
78700435	PV101-C Configuration Tool Kit	User Configuration Tool	
78700244	PV101-A	Murphy STD	English, Spanish, French, Italian, German
78700396	PV101-A-M01	Murphy STD Russian	English, Russian
78700409	PV101-A-M02	Murphy STD Chinese*	English, Chinese
78700411	PV101-A-M03	Murphy STD Japanese*	English, Japanese

*Added features not available in these language models.

SALES CONTACT



CONTACT

✉ sales@rajkotmarinelc.ae
 ☎ +971 6 7487580
 🌐 www.rajkotmarine.com

RAJKOT MARINE LLC

Jerf Industrial Area 1,
 P.O Box 5861
 Ajman, UAE

